

A time-sorting insect light trap

S. ACHIM NIELSEN, K. E. SIEWERTZ-POULSEN & B. OVERGAARD NIELSEN

Nielsen, S. Achim, Siewertz-Poulsen, K. E. & Nielsen, B. Overgaard: A time-sorting insect light trap.

Ent. Meddr, 48: 29–32. Copenhagen, Denmark 1980. ISSN 0013-8851.

An automatic time-sorting insect light trap with a suction fan incorporated is presented. The trap is well suited for the sampling of small insects, for instance Ceratopogonidae and Psychodidae (Diptera), but it is easily modified with a view to larger insects. Daily sampling can be done for about 3 weeks without tending; the trap is reliable and the insects collected are well preserved.

S. Achim Nielsen, K. E. Siewertz-Poulsen & B. Overgaard Nielsen, Zoologisk Laboratorium, Ole Worms allé, Bygning 135, DK-8000 Århus C, Denmark.

Introduction

In connection with investigations on the ecology of Danish biting midges (*Culicoides* Latr., Diptera: Ceratopogonidae), simultaneous, large scale sampling in several habitats was required. Species composition, physiological stages of females, seasonal and diurnal periodicity of flight, relationship between flying activity and weather conditions, and other aspects were considered. In several studies on biting midges light traps have been used (cf. Belton and Pucat, 1967, Kettle, 1977); in the present study an efficient, automatic time-sorting trap, collecting undamaged biting midges preserved in a liquid was required. Since the trap was generally left unattended for several weeks, reliable running for long periods was needed, irrespective of weather conditions. A modified light trap satisfying these demands is presented and the applicability of the trap is discussed.

Constructional and functional details

The light trap consists of a PVC box (Fig. 1, 2), containing a choke coil and a motor as well as other components of the sample-changing equipment. By means of switches mounted on the front of the PVC box the bulb and the fan can be checked independently of the time switch; further, the sample-changing equipment can be operated manually. The power supply of the light trap is switched off by means of a

master switch fitted with a warning lamp. On the top of the PVC box two horizontal circular PVC-discs are mounted on a PVC tube (Fig. 1, 2). The upper PVC disc carries round its edge 24 holes at equal intervals, each provided with a vial (70 ml) (Fig. 1).

By means of a PVC-cover carrying a notch for the base of the socket of the funnel (Fig. 1) evaporation from the vials and contamination of the samples are reduced; benzoic acid (50%) was used as a preservative.

The socket of the funnel is made from PVC-tube carrying a notch for the horizontal circular discs, which are free to rotate in a horizontal plane in such a way as to bring the vials in turn exactly beneath the lower end of the socket of the funnel. The upper end of the socket is covered by a PVC-disc in the centre of which a copper pipe stub is mounted (Fig. 2). To the stub a funnel of fine-meshed copper gauze (mesh 196/cm²) is welded (Fig. 2); the upper end of the gauze funnel is attached to a PVC-tube mounted on three vertical bars (Fig. 2). In the centre of the tube a suction fan is mounted with the blades in a horizontal plane (220V, 65W, EBM-DM90-60V₁-E2a; 400 m³/h.).

On top of the fan house an aluminium funnel is mounted (Fig. 1, 2), carrying a cap (aluminium tube) equipped with a light source, e.g. a mercury-vapour bulb.

When small insects, for instance biting midges, are collected, the cap is covered by

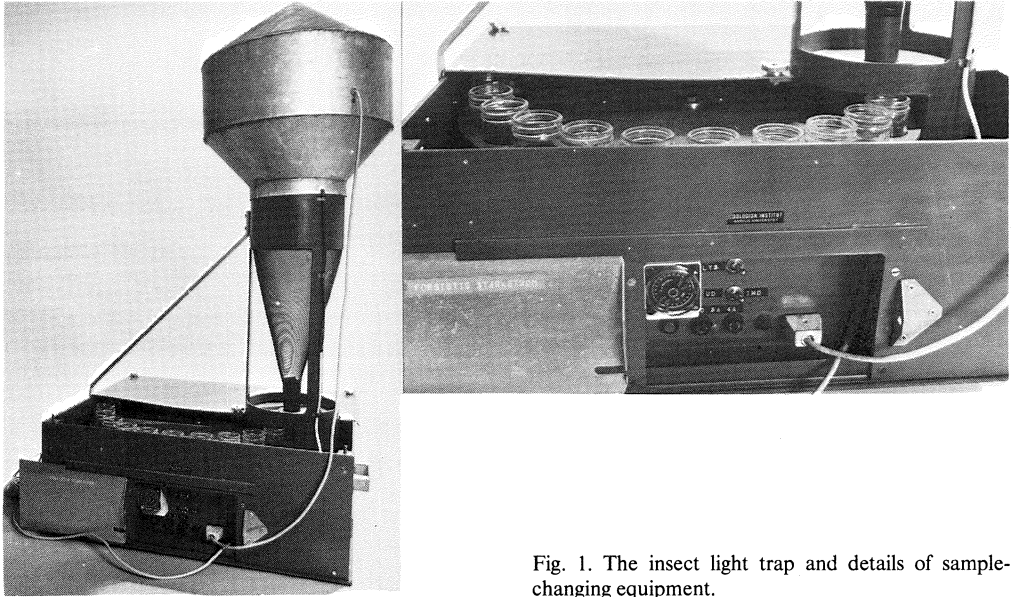

Fig. 1. The insect light trap and details of sample-changing equipment.

copper gauze (mesh 25/cm²); when the cap and the bulb are removed, the trap can be used as a suction trap.

By means of a worm, a crank, and a connecting rod a motor is connected to a device (A)

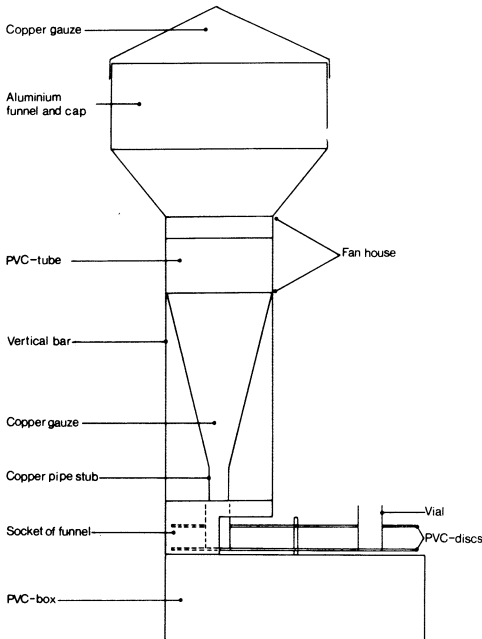

Fig. 2. Sectional view of light trap.

revolving round an axle on which a ratchet wheel carrying 24 teeth and the horizontal circular PVC-discs are mounted (Fig. 3). The device (A) is locked by means of the ratchet wheel and a ratchet (Fig. 3). By means of a notch in the cone-shaped part of the device (A) the latter is connected to a microswitch.

The motor and the microswitch are arranged in a circuit (Fig. 4), which is not commented on, since several alternative designs are possible. An electrical pulse to the motor causes the sample-changing device to rotate 15°, which means that a vial is changed, after which the current is switched off by the microswitch.

A 220-V mains-operated time-switch was used to turn the light on and off once in 24 hours, so that it remained on all night. The sample changing mechanism is controlled by means of another 220-V mains operated time-switch, closing at intervals of 10, 20, 30, or 60 minutes. The latter time-switch can be put out of action by means of a switch, which means that the sample changing mechanism is only activated when the light is turned on. When both time-switches are put in action, the catch is segregated at predetermined time intervals, viz. 10, 20, 30, or 60 minutes.

In the field the trap is protected against rain by means of a pent roof.

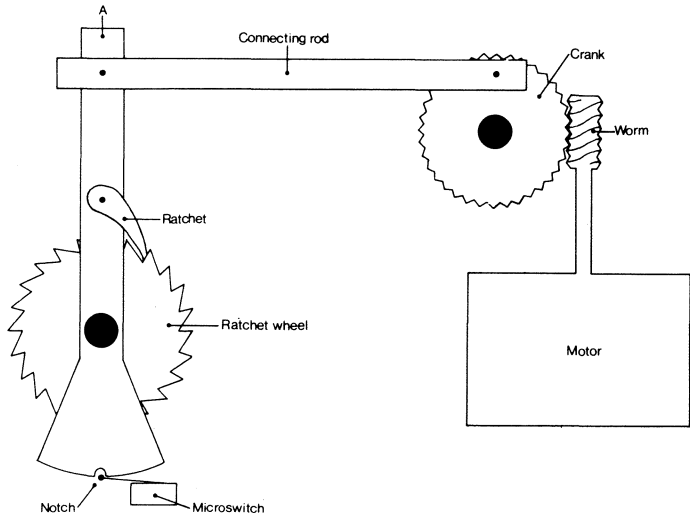

Fig. 3. Partial section of the sample-changing mechanism.

Discussion

Several factors influence light trap efficiency; for instance, a fan is usually necessary to draw down into the light trap small weakly flying insects (Service, 1976). The effect of the fan applied in the light trap presented above was observed in the field; ceratopogonids and other small insects attracted to the light trap and landing on the screen (about 18 cm from the light source) were unable to take off, being immediately drawn down into the killing bottles.

The daily activity of several species of biting midges recorded by light trapping is presented elsewhere. It is, however, noteworthy that the number of ceratopogonids trapped closely

reflected the air temperature recorded; this suggested that specimens attracted by the light were immediately drawn into the vials, ensuring an accurate record of fluctuations in activity.

The light trap presented is well suited for the sampling of small insects, for instance Ceratopogonidae and Psychodidae (Diptera), but it is easily modified with a view to larger specimens. Insects attracted to the light source are immediately drawn down into the vials and well preserved without delay.

The presettable light trap permits a varied sampling programme and continuous daily sampling in several scattered sites can be carried out simultaneously for about 3 weeks without tending.

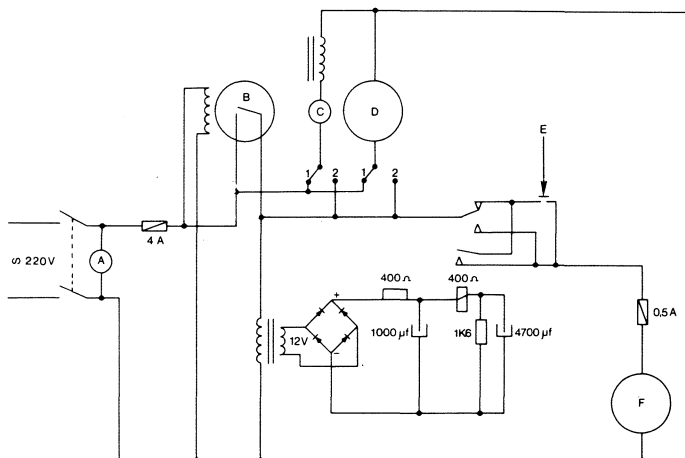

Fig. 4. Circuit. A. Warning lamp, B. Time-switch, C. Mercury-vapour bulb, D. Suction fan, E. Pushbutton for manual operation of the sample-changing equipment, F. Motor of sample-changing equipment, including microswitch. Time-switch for the control of sample-changing mechanism not indicated.

References

- Belton, P. & Pucat, A., 1967: A comparison of different lights in traps for *Culicoides* (Diptera: Ceratopogonidae). – *Can. Ent.* 99: 267–272.
- Kettle, D. S., 1977: Biology and bionomics of blood-sucking Ceratopogonids. – *Ann. Rev. Ent.* 22: 33–51.
- Service, M. W., 1976: *Mosquito Ecology. Field Sampling Methods.* Applied Science Publishers LTD. London.

Anmeldelse

Harwood, Robert F. and James, Maurice T. 1979: *Entomology in human and animal health.* 7. edition. Macmillan Publishing Co., Inc.: 548 pp. Pris 348 kr.

Den foreliggende bog byder på behagelig læsning. Format, tryk, papirkvalitet og illustrationer er i orden og for de sidstes vedkommende ofte enkle og instruktive på samme tid.

Teksten er opdelt i velmotiverede afsnit, der hver for sig er disponerede efter samme model, hvad der giver mulighed for hurtig orientering i stoffet. Yderligere er bogen skrevet i en let tilgængelig, flydende form uden urimelig megen anvendelse af fagudtryk. Hertil kommer et fyldigt stikordsregister og en omfattende litteraturliste til brug bl.a. ved videregående selvstudium.

Af bogens sytten hovedafsnit er de fem af tværfaglig karakter med omtale af insekters og spindleres almene bygning, klassifikation, munddeles struktur og funktion, epidemiologi, produktion af gifte og allergener samt med angivelse af, hvordan de vigtigste af skadeforvolderne bedst og billigst kan bekæmpes med særlig vægt lagt på en redegørelse for de dertil hørende biologiske metoders anvendelighed.

Af de resterende kapitler er fem reserveret diptererne, og her, ligesom under afsnittene omhandlende flåterne, findes der særdeles værdifulde oversigter over de sygdomsforvoldere, disse kan overføre til husdyr og mennesker. Man præsenteres her bl.a. for en lang

Sammendrag:

En lysfælde til automatisk tidsinddelt registrering af insektfangst.

En programmérbar lysfælde til automatisk tidsinddelt registrering af insektfangst beskrives. Insekter tiltrukket af lyset suges ved hjælp af en ventilator ned i glas indeholdende benzoesyre, hvilket sikrer velkonserverede prøver. Fælden, der er meget driftssikker, kan uden tilsyn benyttes til daglige indsamlinger af insekter gennem perioder på op til 3 uger. Fælden beskyttes mod regn ved opstilling under et halvtag. Den er især velegnet til indsamling af små insekter, f. eks. mitter (Ceratopogonidae) og sommerfuglemyg (Psychodidae), men kan let modificeres med henblik på fangst af større insekter. Lysfælden kan programmeres til at indsamle én prøve pr. døgn eller hver prøve kan repræsentere en indsamlingsperiode på 10, 20, 30 eller 60 minutter.

række af virusformer, som jeg tror vil være ubekendte for hovedparten af danske læsere.

I de øvrige kapitler behandles særlig grundigt tæger og lus, men også mindre betydningsfulde grupper omtales som f.eks. sommerfugle, nemlig i forbindelse med de arter, hvis snabler er forholdsvis korte, spidse og tornede, beregnet til opsugning af tårevædske fra inderside af øjenlåg eller ligefrem til at gennembore huden med og suge blod.

For f.eks. flere arter af biller og kakerlakker nævnes hvorledes de på deres overflader eller via tarmkanal kan overføre sygdomsforvoldende bakterier og virus, og også hvordan vi ved kontakt med selve disse dyr, eller ved berøring eller indånding af udstødte huder eller hår fra disse, kan pådrage os alvorlige overfølsomheds sygdomme.

I tilslutning til de mere parasitologiske forhold gøres der også og i rimeligt omfang rede for den almene levevis for hovedparten af de omtalte insekter og spindlere.

I deres valg af eksempler er bogen præget af, at bøgerne forfatterne er amerikanere, men det forhindrer dog ikke, at den med godt udbytte kan studeres også af danske læsere, såvel til belysning af forhold her i landet som til orientering i, hvad man kan komme ud for som rejsende i landene syd for os, hvor ukendskab til derværende parasitiske insekters og spindleres forekomst og kliniske betydning kan få fatale følger for os selv som for de husdyr, vi måtte forsøge at indføre til sådanne steder.

Niels Haarløv